

| Ø DE | Ø Filo Wire | Nsp Spire Coils | H | Molata Grinstoned * | Materiale Material | Codice Code | Versione Version |
|------|-------------|-----------------|------|---------------------|--------------------|-------------|------------------|
| 9,6 | 1,6 | 4 | 14,5 | Si -Yes | Inox | MMC001 | 01 |
| 7,5 | 1,2 | 4 | 12 | Si -Yes | Inox | MMC002 | 01 |
| 19,2 | 3,2 | 8 | 38 | Si -Yes | Inox | MMC003 | 01 |
| 18 | 1,8 | 10 | 70 | Si -Yes | Inox | MMC004 | 01 |
| 12 | 1,4 | 11 | 47 | Si -Yes | Inox | MMC005 | 01 |
| 14,5 | 1 | 7 | 39 | No - Not | Inox | MMC006 | 01 |
| 17 | 2 | 6 | 29 | Si -Yes | Inox | MMC007 | 01 |
| 20,8 | 0,8 | 13 | 41,5 | No - Not | Inox | MMC008 | 01 |
| 20,7 | 1,1 | 17 | 122 | No - Not | Inox | MMC009 | 01 |
| 19,2 | 1,8 | 20 | 92 | No - Not | Inox | MMC010 | 01 |
| 24 | 2 | 12 | 81 | Si -Yes | Inox | MMC011 | 01 |
| 20 | 2 | 7 | 41,5 | Si -Yes | Inox | MMC012 | 01 |
| 23 | 2 | 7 | 62 | Si -Yes | Inox | MMC013 | 01 |
| 31 | 2,4 | 8 | 60,5 | Si -Yes | Inox | MMC014 | 01 |
| 41,4 | 3,5 | 5 | 60 | Si -Yes | Inox | MMC015 | 01 |
| 7 | 0,7 | 7 | 15 | Si -Yes | Inox | MMC016 | 01 |
| 34,8 | 3,5 | 10 | 70 | Si -Yes | Inox | MMC017 | 01 |
| 7,5 | 0,5 | 8 | 17 | No - Not | Inox | MMC018 | 01 |
| 11 | 1,2 | 9 | 24 | Si -Yes | Inox | MMC019 | 01 |
| 6,9 | 0,8 | 11 | 23 | No - Not | Inox | MMC020 | 01 |
| 11,8 | 1 | 9 | 35 | No - Not | Inox | MMC021 | 01 |
| 7 | 0,8 | 6 | 14 | No - Not | Inox | MMC022 | 01 |
| 10 | 1 | 12 | 45,8 | Si -Yes | Inox | MMC023 | 01 |
| 25 | 1,8 | 9 | 63 | Si -Yes | Inox | MMC024 | 01 |
| 11,5 | 1 | 6 | 25 | Si -Yes | Inox | MMC025 | 01 |
| 5,5 | 0,5 | 6 | 9,4 | Si -Yes | Inox | MMC026 | 01 |
| 26,4 | 1,7 | 17 | 146 | Si -Yes | Inox | MMC027 | 01 |
| 19 | 0,7 | 11 | 64 | No - Not | Inox | MMC028 | 01 |
| 8,9 | 0,9 | 13 | 36 | Si -Yes | Inox | MMC029 | 01 |

| Ø DE | Ø Filo Wire | Nsp Spire Coils | H | Molata Grinstoned * | Materiale Material | Codice Code | Versione Version |
|------|-------------|-----------------|------|---------------------|--------------------|-------------|------------------|
| 7,2 | 0,8 | 4 | 12 | Si -Yes | Inox | MMC030 | 01 |
| 23,1 | 2,3 | 19 | 176 | Si -Yes | Fe | MMC031 | 01 |
| 11 | 1 | 7 | 20 | No - Not | Inox | MMC032 | 01 |
| 29 | 1,8 | 17 | 102 | Si -Yes | Inox | MMC033 | 01 |
| 28,7 | 2,5 | 22 | 124 | Si -Yes | Inox | MMC034 | 01 |
| 43,4 | 3,2 | 7 | 125 | Si -Yes | Inox | MMC035 | 01 |
| 14 | 1 | 10 | 68 | Si -Yes | Inox | MMC036 | 01 |
| 19 | 2 | 9 | 64 | Si -Yes | Inox | MMC037 | 01 |
| 34,1 | 2,8 | 10 | 150 | Si -Yes | Inox | MMC038 | 01 |
| 10 | 1 | 25 | 120 | No - Not | Inox | MMC039 | 01 |
| 14 | 1,5 | 10 | 50 | Si -Yes | Inox | MMC040 | 01 |
| 11 | 1 | 8 | 25 | Si -Yes | Inox | MMC041 | 01 |
| 24 | 2 | 13 | 90 | No - Not | Inox | MMC042 | 01 |
| 24 | 1 | 10 | 77 | No - Not | Inox | MMC043 | 01 |
| 20 | 1,5 | 10 | 60 | Si -Yes | Inox | MMC044 | 01 |
| 25 | 1,5 | 6 | 54 | Si -Yes | Inox | MMC045 | 01 |
| 19 | 0,8 | 11 | 70 | No - Not | Inox | MMC046 | 01 |
| 10 | 0,5 | 9 | 35 | No - Not | Inox | MMC047 | 01 |
| 9 | 0,8 | 14 | 37 | Si -Yes | Inox | MMC048 | 01 |
| 8 | 0,8 | 6 | 13,5 | Si -Yes | Inox | MMC049 | 01 |
| 13 | 0,5 | 12 | 39 | No - Not | Inox | MMC050 | 01 |
| 14 | 1,5 | 13 | 67 | Si -Yes | Inox | MMC051 | 01 |
| 10 | 1 | 12 | 32 | Si -Yes | Inox | MMC052 | 01 |
| 11 | 1 | 10 | 25 | Si -Yes | Inox | MMC053 | 01 |
| 9,5 | 0,8 | 11 | 32 | Si -Yes | Inox | MMC054 | 01 |
| 11,5 | 1,2 | 7 | 22 | Si -Yes | Inox | MMC055 | 01 |
| 9 | 1 | 7 | 24 | Si -Yes | Inox | MMC056 | 01 |
| 19 | 1 | 22 | 152 | Si -Yes | Inox | MMC057 | 01 |
| 18 | 1,5 | 6 | 18 | Si -Yes | Inox | MMC058 | 01 |
| 19 | 0,8 | 22 | 66 | No - Not | Inox | MMC059 | 01 |
| 14,2 | 1,2 | 8 | 25 | Si -Yes | Inox | MMC060 | 01 |
| 26 | 1,8 | 17 | 148 | Si -Yes | Inox | MMC061 | 01 |
| 19,5 | 2,2 | 24 | 135 | No - Not | Inox | MMC062 | 01 |
| 25 | 1,2 | 20 | 143 | No - Not | Inox | MMC063 | 01 |
| 37 | 2,8 | 13 | 139 | Si -Yes | Inox | MMC064 | 01 |
| 38,5 | 2 | 8 | 69 | No - Not | Inox | MMC065 | 01 |
| 26 | 1,8 | 6 | 30 | No - Not | Inox | MMC066 | 01 |
| 26 | 1,8 | 8 | 31 | No - Not | Inox | MMC067 | 01 |
| 20 | 1,5 | 5 | 30 | Si -Yes | Inox | MMC068 | 01 |
| 20 | 1,5 | 6 | 30 | Si -Yes | Inox | MMC069 | 01 |
| 20 | 1,8 | 6 | 30 | Si -Yes | Inox | MMC070 | 01 |
| 15 | 1 | 8 | 30 | Si -Yes | Inox | MMC071 | 01 |
| 22 | 2,5 | 4 | 18 | Si -Yes | Inox | MMC072 | 01 |

| Ø Øf DE | Nsp Filo Wire | H Spire Coils | Molata | Materiale Grinstoned * | Codice Material | Versione Code | Version |
|------------|---------------------|---------------------|--------|------------------------------|--------------------|------------------|---------|
| 21,5 | 1,5 | 10 | 90 | No - Not | Inox | MMC073 | 01 |
| 17,7 | 1,2 | 18 | 90 | Si -Yes | Inox | MMC074 | 01 |
| 16,2 | 1,2 | 8 | 30 | Si -Yes | Inox | MMC075 | 01 |
| 15,5 | 1,5 | 12 | 60 | Si -Yes | Inox | MMC076 | 01 |
| 16,5 | 1,5 | 8 | 30 | Si -Yes | Inox | MMC077 | 01 |
| 21,2 | 1,2 | 32 | 245 | Si -Yes | Inox | MMC078 | 01 |
| 46 | 3 | 7 | 110 | Si -Yes | Inox | MMC079 | 01 |
| 15,1 | 1,5 | 22 | 110 | Si -Yes | Inox | MMC080 | 01 |
| 26 | 1,8 | 18 | 108 | Si -Yes | Inox | MMC081 | 01 |
| 15,5 | 2,3 | 3 | 18 | Si -Yes | Inox | MMC082 | 01 |
| 22 | 2 | 10 | 80 | Si -Yes | Inox | MMC083 | 01 |
| 19 | 1,5 | 9 | 180 | No - Not | Inox | MMC084 | 01 |
| 19,8 | 2,8 | 5 | 33 | No - Not | Inox | MMC085 | 01 |
| 33,7 | 2 | 8 | 100 | Si -Yes | Inox | MMC086 | 01 |
| 35 | 2 | 11 | 91 | Si -Yes | Inox | MMC087 | 01 |
| 17 | 1 | 11 | 44 | Si -Yes | Inox | MMC088 | 01 |
| 10 | 0,5 | 12 | 30 | Si -Yes | Inox | MMC089 | 01 |
| 39,4 | 2,2 | 10 | 120 | No - Not | Inox | MMC090 | 01 |
| 24 | 2,2 | 24 | 235 | No - Not | Inox | MMC091 | 01 |
| 13 | 1 | 7 | 22 | Si -Yes | Inox | MMC092 | 01 |
| 5,5 | 0,5 | 9 | 8 | Si -Yes | Inox | MMC093 | 01 |
| 15,5 | 2 | 4 | 14,5 | Si -Yes | Inox | MMC094 | 01 |
| 19,6 | 0,7x2,5 | 21 | 124 | Si -Yes | Inox | MMC095 | 01 |
| 39,4 | 2,2 | 8 | 95 | No - Not | Inox | MMC096 | 01 |
| 30 | 2,2 | 12 | 110 | No - Not | Inox | MMC097 | 01 |
| 15,5 | 2,3 | 5 | 18 | Si -Yes | Inox | MMC098 | 01 |
| 8,3 | 0,7 | 20 | 39 | Si -Yes | Inox | MMC099 | 01 |
| 31,9 | 1,8 | 15 | 178 | Si -Yes | Inox | MMC100 | 01 |
| 11 | 1 | 10 | 31 | Si -Yes | Inox | MMC101 | 01 |
| 17,5 | 1,6 | 5 | 25 | No - Not | Inox | MMC102 | 01 |
| 9,5 | 1 | 10 | 31 | Si -Yes | Inox | MMC103 | 01 |
| 15 | 2,5 | 21 | 97 | Si -Yes | Fe | MMC104 | 01 |
| 11,5 | 1,4 | 15 | 42 | Si -Yes | Inox | MMC105 | 01 |
| 24,8 | 1,8 | 6 | 54 | Si -Yes | Inox | MMC106 | 01 |
| 9,2 | 1 | 13 | 35 | Si -Yes | Inox | MMC107 | 01 |
| 20 | 1,4 | 16 | 110 | Si -Yes | Inox | MMC108 | 01 |
| 17,8 | 1,2 | 7 | 28 | No - Not | Inox | MMC109 | 01 |
| | | | | | | | |
| | | | | | | | |
| | | | | | | | |
| | | | | | | | |
| | | | | | | | |

MOLLE MMN

Springs mmn

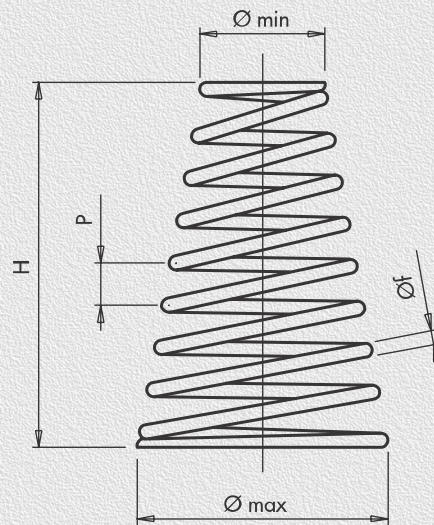

| L | D1 | D2 | df | P | Nsp | Molata Grindstoned | Materiale Material | Codice Code | Versione Version |
|-----|-----|-----|-----|-----|-----|-----------------------|-----------------------|----------------|---------------------|
| 20 | 9 | 4 | 0,5 | 1,5 | 14 | No-Not | Inox | MMN001 | 01 |
| 25 | 12 | 8 | 1 | 6 | 6 | Si-Yes | Inox | MMN002 | 01 |
| 13 | 8,9 | 4,5 | 0,5 | 1,5 | 9 | Si-Yes | Inox | MMN003 | 01 |
| 135 | 32 | 24 | 1,8 | 7,7 | 19 | Si-Yes | Inox | MMN004 | 01 |
| 50 | 15 | 14 | 1,2 | 4,2 | 15 | No-Not | Inox | MMN005 | 01 |
| 22 | 11 | 8,5 | 1 | 3,3 | 8 | Si-Yes | Inox | MMN006 | 01 |
| 55 | 45 | 38 | 1,5 | 17 | 5 | Si-Yes | Inox | MMN007 | 01 |
| 25 | 12 | 8 | 1 | 4,2 | 7 | Si-Yes | Inox | MMN011 | 01 |

MMN00801

N° Spire 13
 Molata no
 N° Coils 13
 Grindstoned not

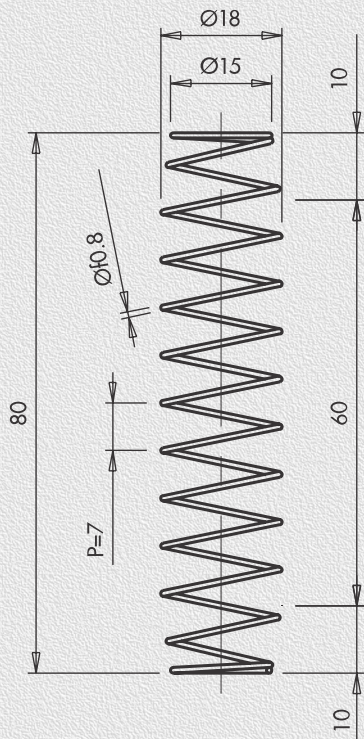

MMN00901

N° Spire 15
 Molata no
 N° Coils 15
 Grindstoned no

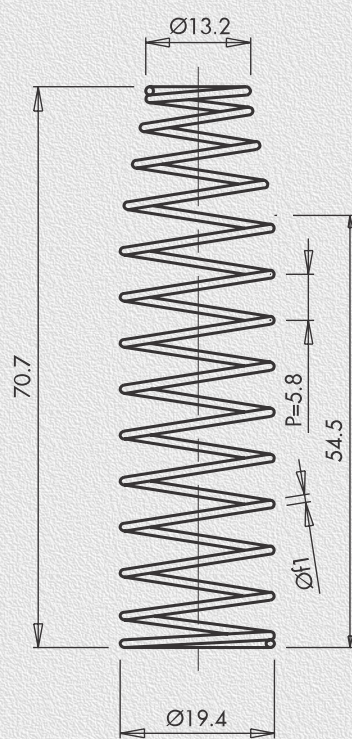

MMN01001

N° Spire 6
 Molata no
 N° Coils 6
 Grindstoned no

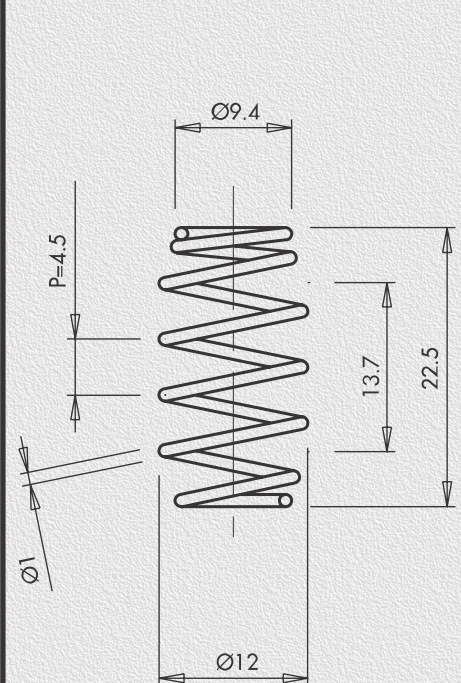

MOLLE MMN

Springs mmn



MMN01201

| | |
|-------------|-----|
| N° Spire | 17 |
| Molata | no |
| N° Coils | 17 |
| Grindstoned | not |

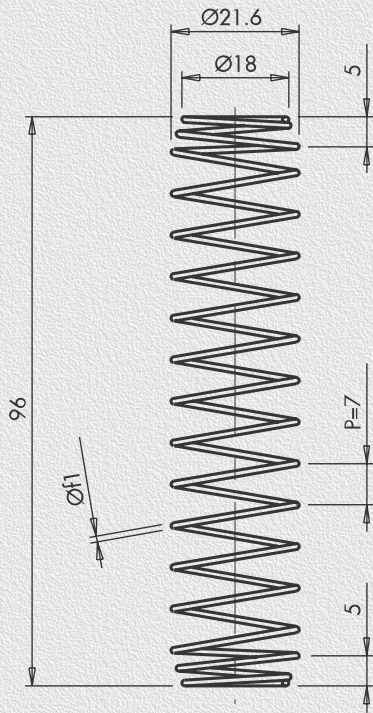

MMN01301

| | |
|-------------|-----|
| N° Spire | 17 |
| Molata | no |
| N° Coils | 17 |
| Grindstoned | not |

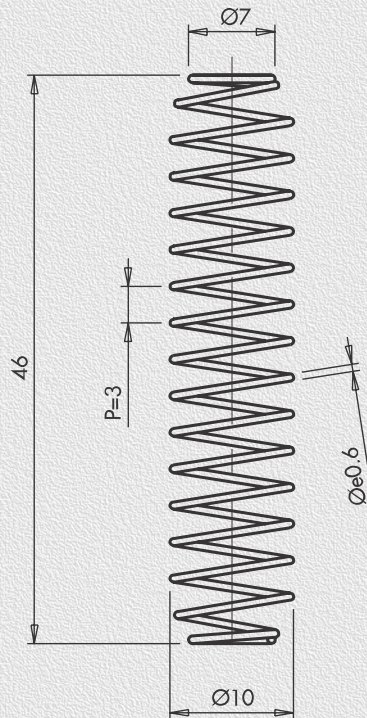

MMN01401

| | |
|-------------|-----|
| N° Spire | 10 |
| Molata | no |
| N° Coils | 10 |
| Grindstoned | not |

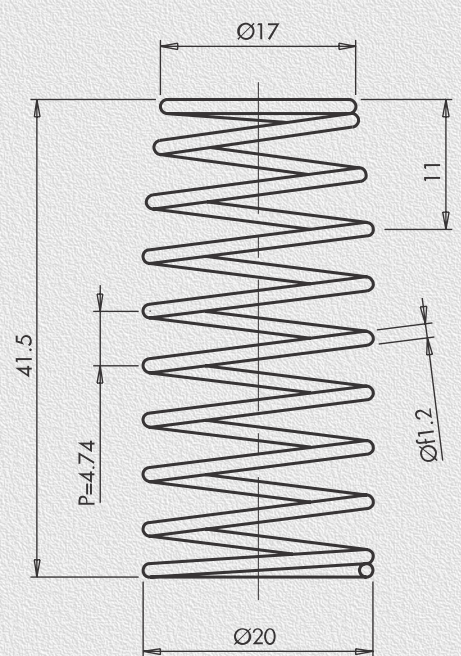

MOLLE MMT

Springs mmt



MMT00101

| | |
|--------------|-----|
| N° Spire | 11 |
| Ganci mobili | si |
| N° Coils | 11 |
| Swivel hook | yes |

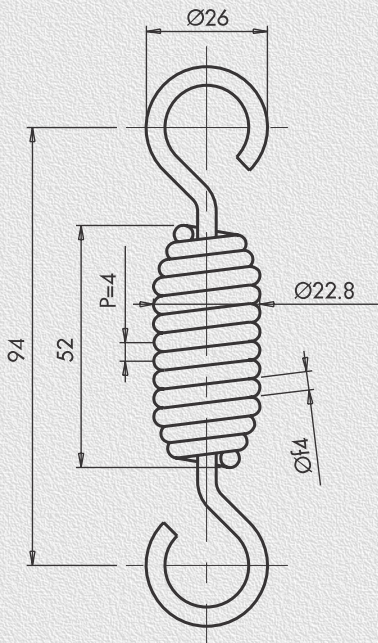

MMT00201

| | |
|--------------|-----|
| N° Spire | 20 |
| Ganci mobili | no |
| N° Coils | 20 |
| Swivel hook | not |

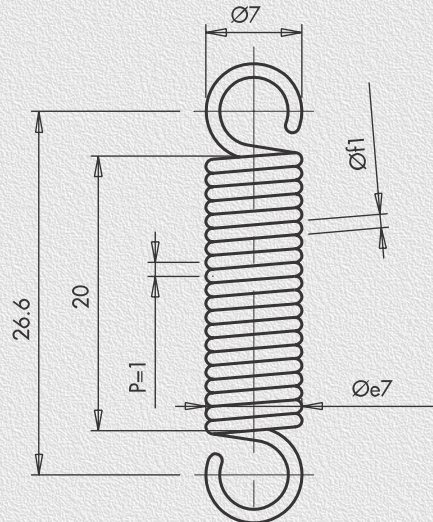

MMT00301

| | |
|--------------|-----|
| N° Spire | 60 |
| Ganci mobili | si |
| N° Coils | 60 |
| Swivel hook | yes |

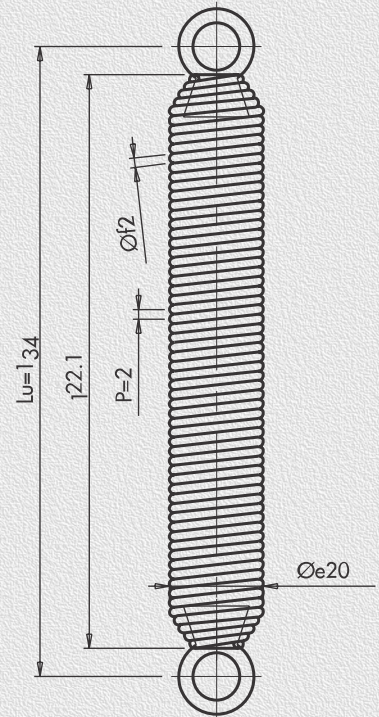

MMT00401

| | |
|--------------|-----|
| N° Spire | 25 |
| Ganci mobili | no |
| N° Coils | 25 |
| Swivel hook | not |

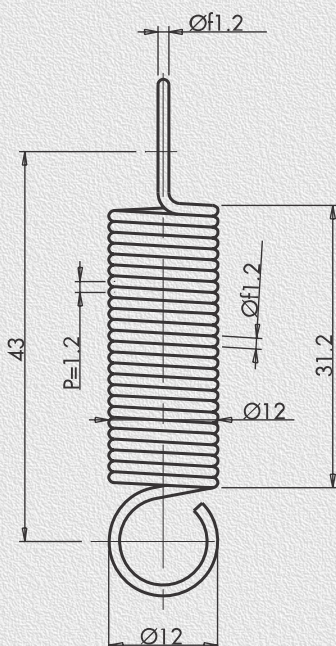

MMT00501

| | |
|--------------|-----|
| N° Spire | 19 |
| Ganci mobili | no |
| N° Coils | 19 |
| Swivel hook | not |

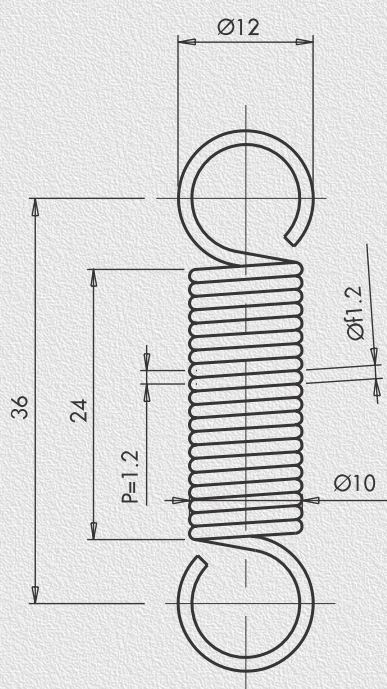

MMT00601

| | |
|--------------|-----|
| N° Spire | 34 |
| Ganci mobili | no |
| N° Coils | 34 |
| Swivel hook | not |

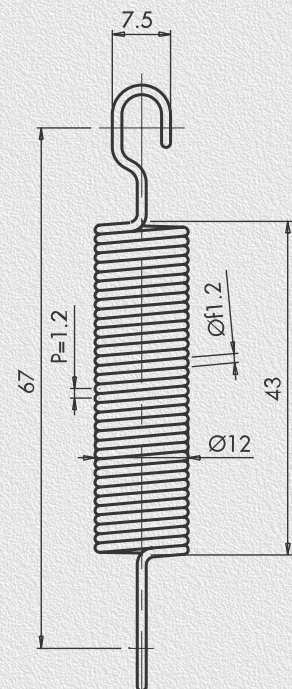

MMT00701

| | |
|--------------|-----|
| N° Spire | 18 |
| Ganci mobili | no |
| N° Coils | 18 |
| Swivel hook | not |

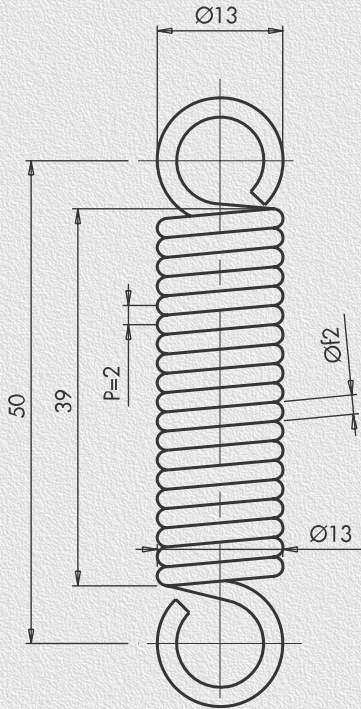

MMT00801

| | |
|--------------|-----|
| N° Spire | 19 |
| Ganci mobili | si |
| N° Coils | 19 |
| Swivel hook | yes |

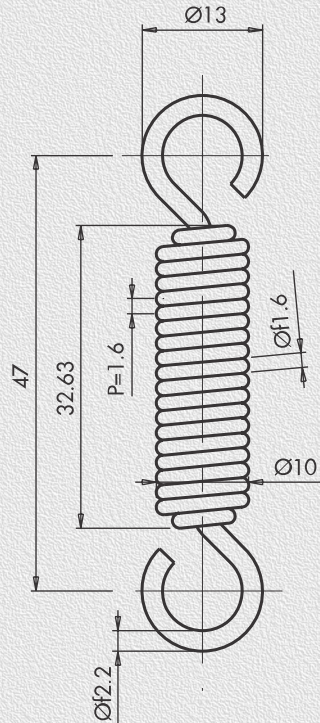

MMT00901

| | |
|--------------|-------|
| N° Spire | 44 |
| Ganci mobili | viti |
| N° Coils | 44 |
| Swivel hook | screw |

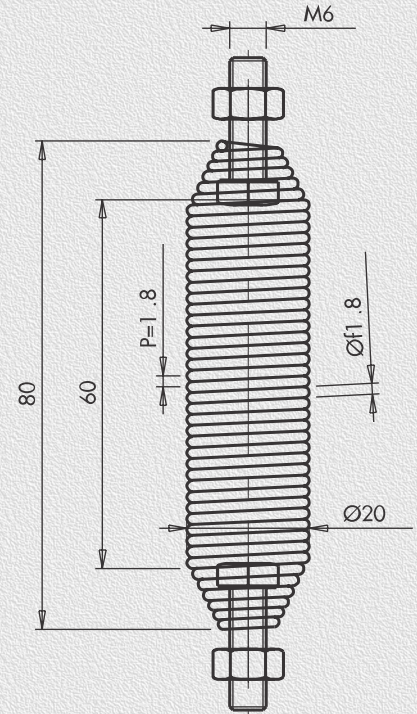

MMT01001

| | |
|--------------|-----|
| N° Spire | 19 |
| Ganci mobili | no |
| N° Coils | 19 |
| Swivel hook | not |

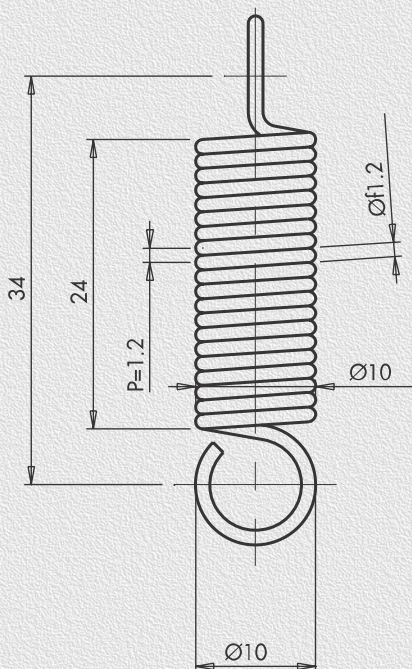

MMT01101

| | |
|--------------|-----|
| N° Spire | 88 |
| Ganci mobili | si |
| N° Coils | 88 |
| Swivel hook | yes |

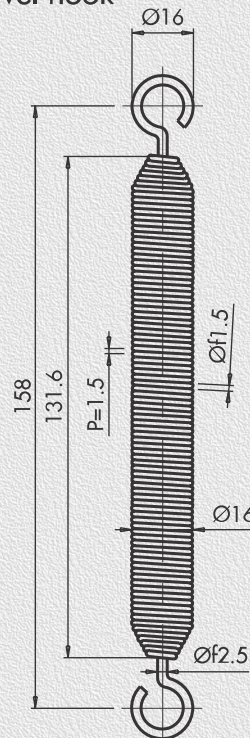

MMT01201

| | |
|--------------|-----|
| N° Spire | 40 |
| Ganci mobili | si |
| N° Coils | 40 |
| Swivel hook | yes |

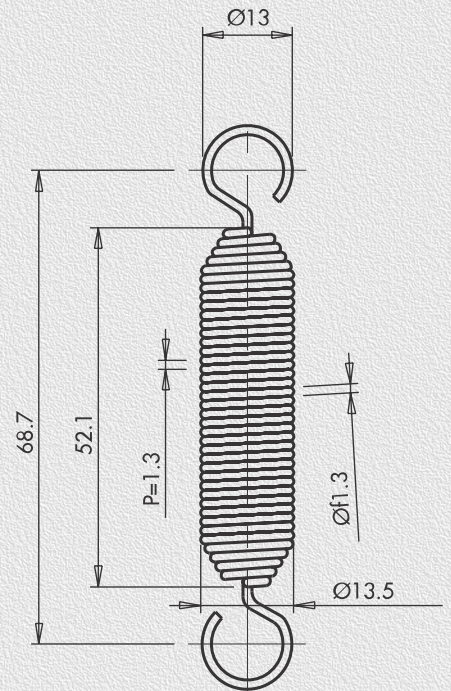

MMT01301

| | |
|--------------|-----|
| N° Spire | 31 |
| Ganci mobili | no |
| N° Coils | 31 |
| Swivel hook | not |

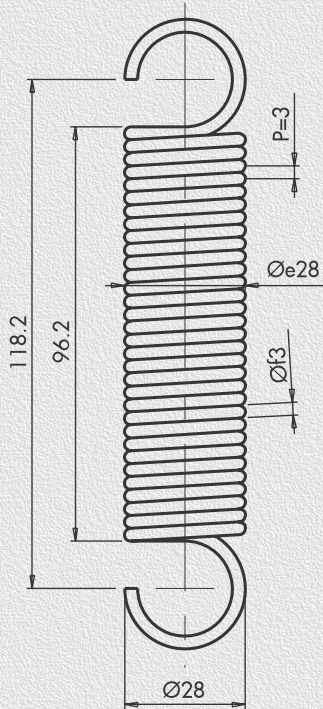

MMT01401

| | |
|--------------|------|
| N° Spire | 24,5 |
| Ganci mobili | si |
| N° Coils | 24,5 |
| Swivel hook | yes |

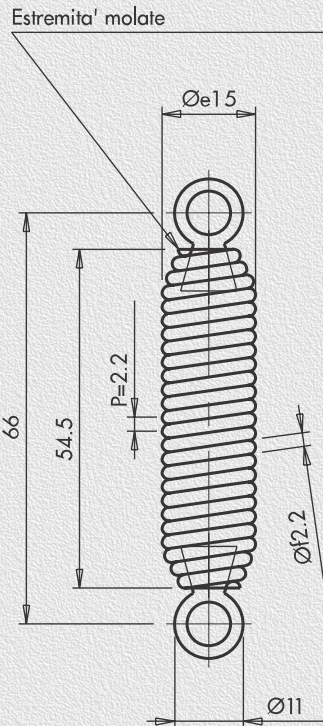

MMP01501

| | |
|--------------|-----|
| N° Spire | 19 |
| Ganci mobili | no |
| N° Coils | 19 |
| Swivel hook | not |

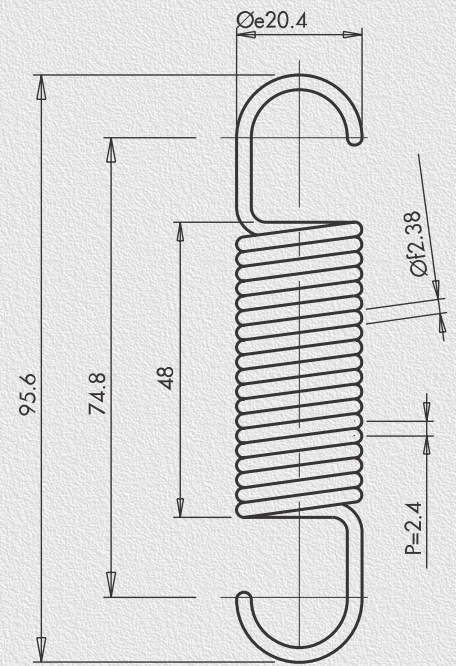

MMT01601

| | |
|--------------|-----|
| N° Spire | 16 |
| Ganci mobili | no |
| N° Coils | 16 |
| Swivel hook | not |

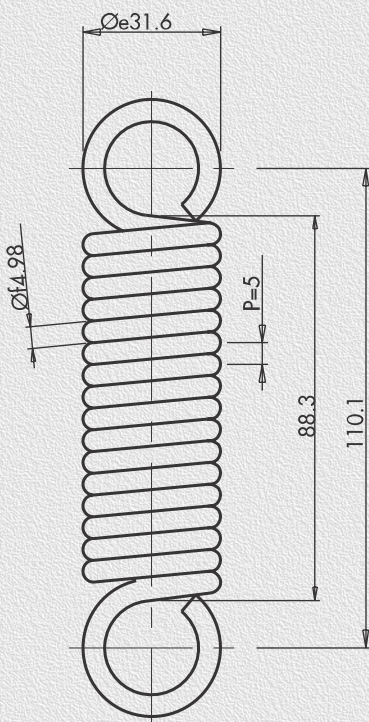

MMT01701

| | |
|--------------|-----|
| N° Spire | 17 |
| Ganci mobili | si |
| N° Coils | 17 |
| Swivel hook | yes |

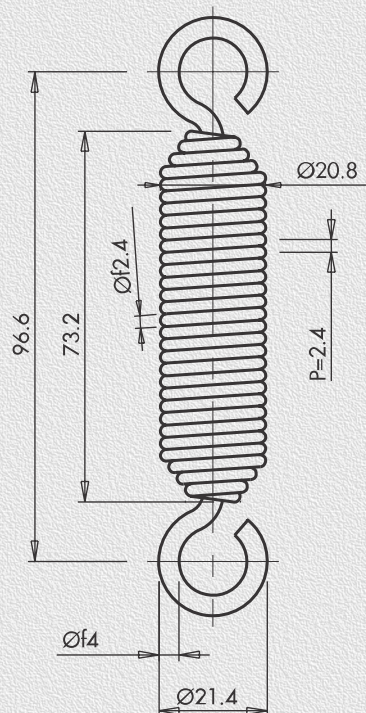

MMT01801

| | |
|--------------|-----|
| N° Spire | 49 |
| Ganci mobili | si |
| N° Coils | 49 |
| Swivel hook | yes |

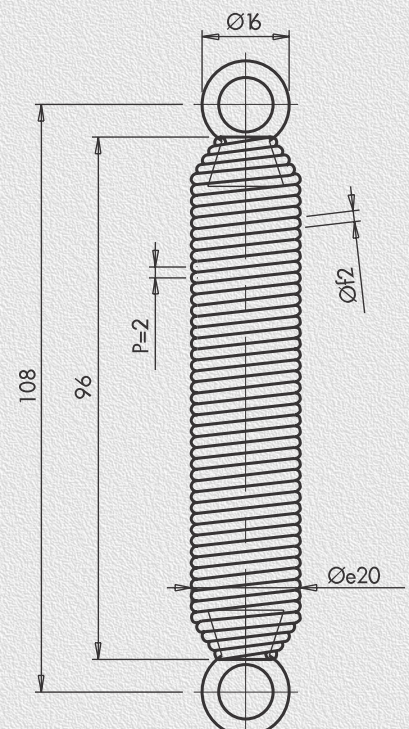

MOLLE MMS

Springs mms



MMS00101

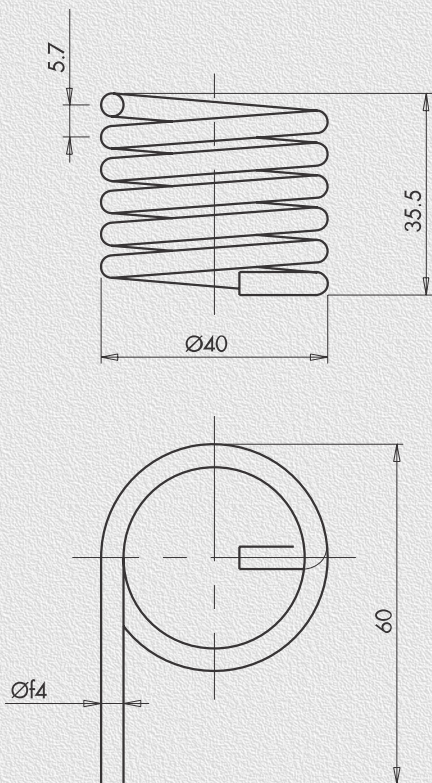

MMS00102

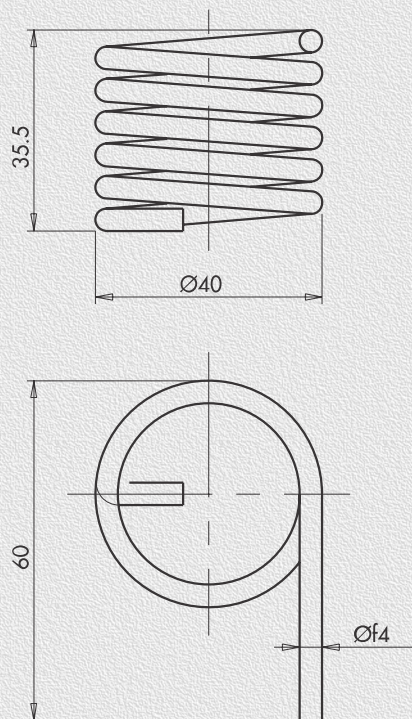

MMS00201

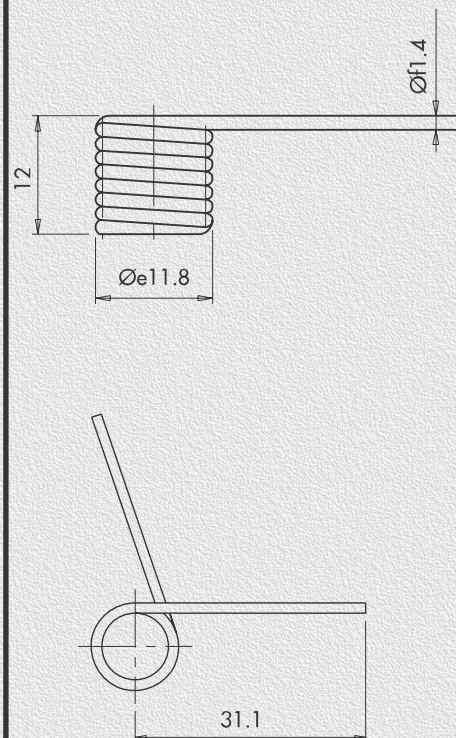

MMS00301

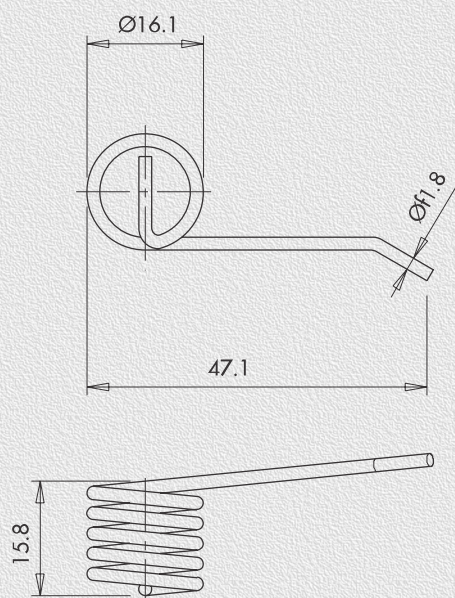

MMS00401

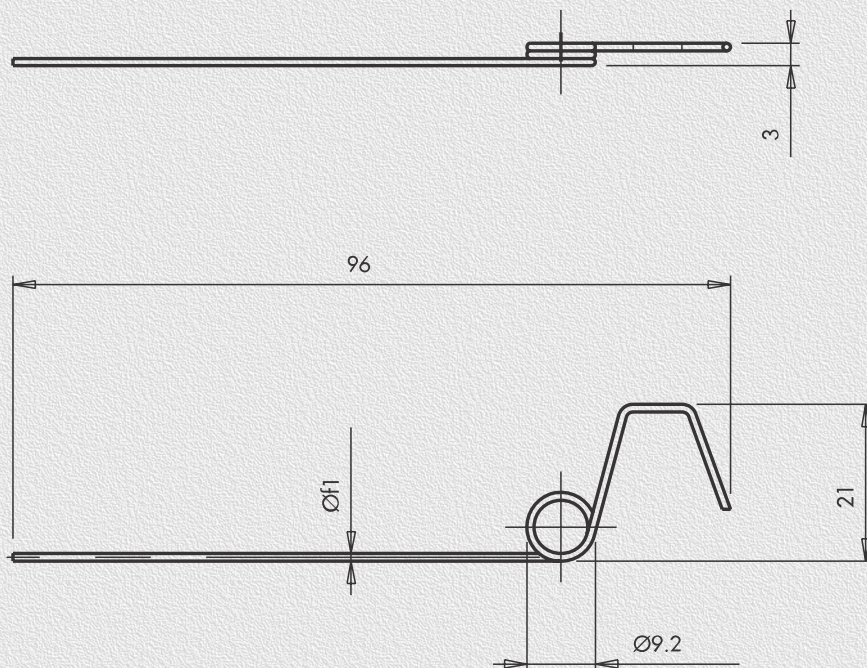

MOLLE MMS

Springs mms



MMS00501

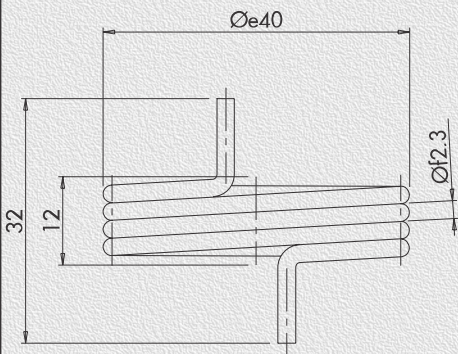

MMS00601

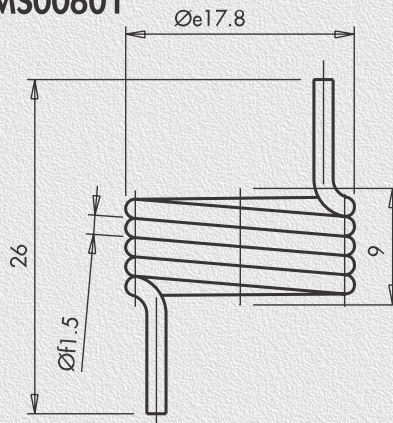

MMP00101

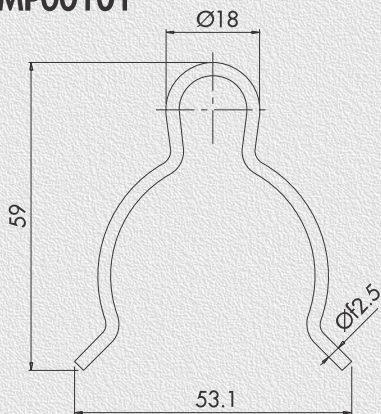

MMP00201

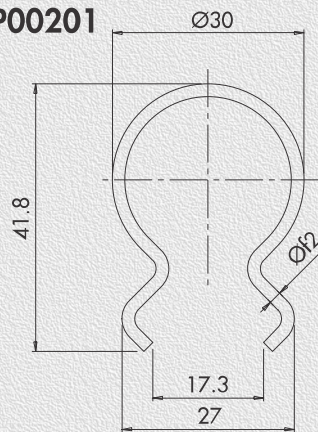

MMP00301

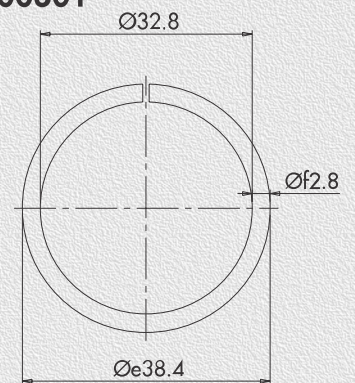

MMZ00101

